

THE BLENDING STATION® ADVANCE, WITH ITS SPACE-SAVING STREAMLINED COVER, HAS 34 BLENDER PROGRAMS OPTIMIZED FOR PERFORMANCE ENHANCEMENT. THESE PROGRAMS WILL BLEND BY FAR THE MAJORITY OF ALL DRINK RECIPES WITH EASE! EACH PROGRAM COMBINES THE RIGHT SPEED AND TIMING TO ELIMINATE THE GUESSWORK AND IS CUSTOMIZABLE FOR SIGNATURE DRINKS WITH A SIMPLE PROGRAMMING CHIP.

BLENDING STATION® ADVANCE	
ITEM NUMBER	DESCRIPTION
36006	On-Counter Blending Station® Advance with 48 oz. / 1.4 Ltr. XP container and blade; compact cover with removable hinge design; pre-programmed with 34 programs
40002	In-Counter Blending Station® Advance with 48 oz. / 1.4 Ltr. XP container and blade; compact cover with removable hinge design; pre-programmed with 34 programs

These Item Numbers are for 120 VAC. Other voltages are also available.

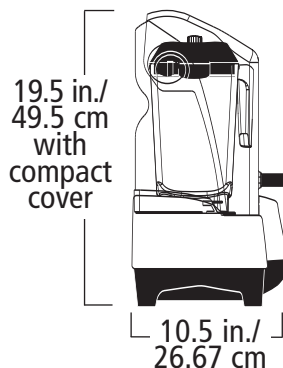
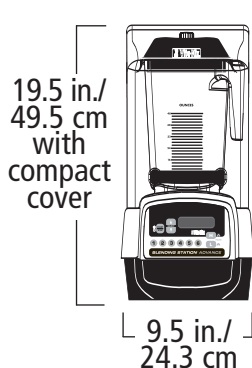

----- 36006 -----

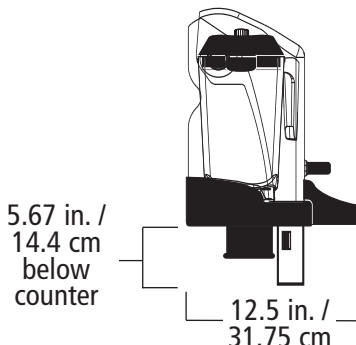
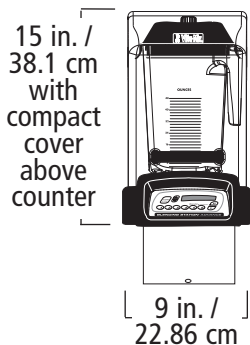

----- 40002 -----

BLENDING STATION® ADVANCE
The "Quiet" Advance Performance Blender

Specifications:

3+ peak motor horsepower with 37,000 RPM bare motor speed

Full range feedback controlled speeds from 1,500 RPM to 22,500 RPM

120 VAC, 50/60 Hz, 15 Amps

Other Voltages Available

Container has XP (Xtreme Performance) blade

On-Counter

Pack: 1 per standard pack

Weight: 19.5 lbs. / 8.9 kg

Cube: 2.3 cu. ft. / .07 cu. m

Case: 13.3 in. / 33.8 cm H x
12.1 in. / 30.7 cm W x
24.2 in. / 61.5 cm D

In-Counter

Pack: 1 per standard pack

Weight: 17.5 lbs. / 7.9 kg

Cube: 2.6 cu. ft. / .07 cu. m

Case: 12.1 in. / 30.7 cm H x
14.8 in. / 37.6 cm W x
24.9 in. / 63.2 cm D

ON-COUNTER

Model # VM0115E

IN-COUNTER

Model # VM0116E



when applicable



FOODSERVICE